

Nicht vermeldetes Material:
Al-Mg Si 1

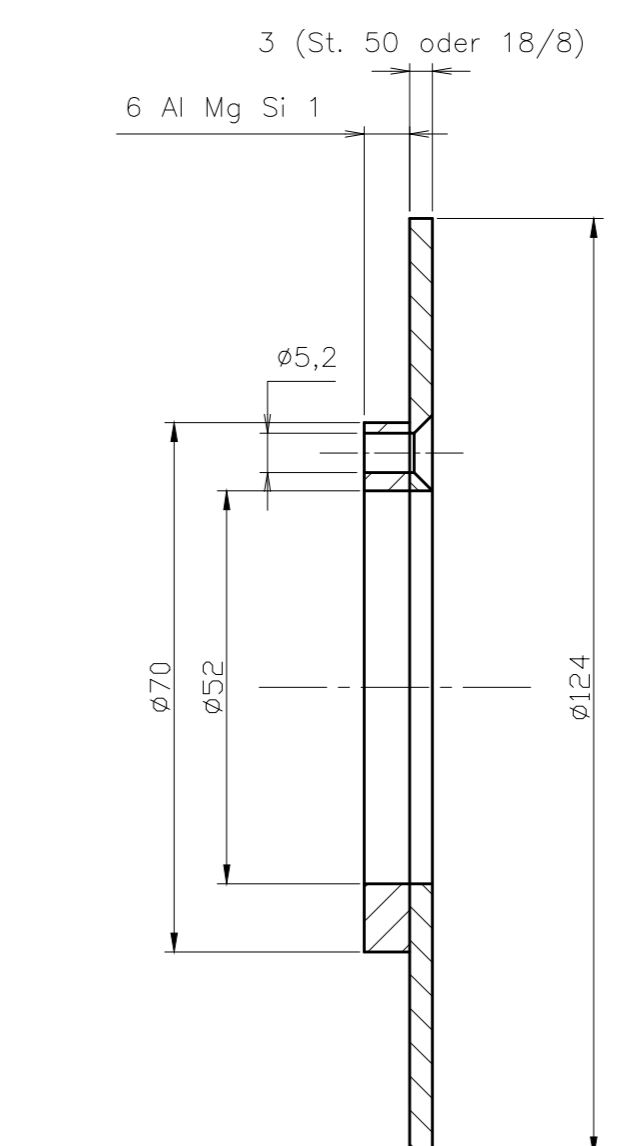
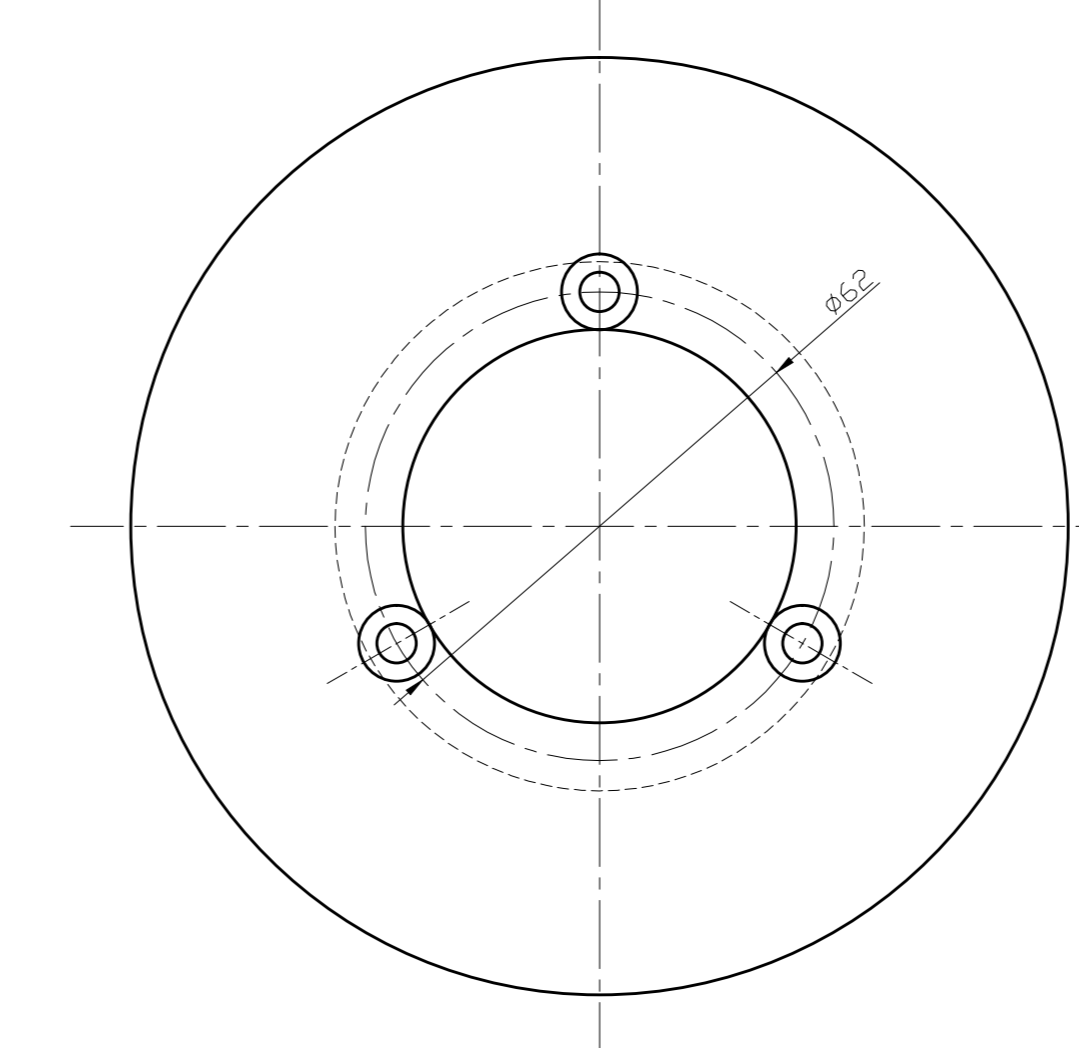
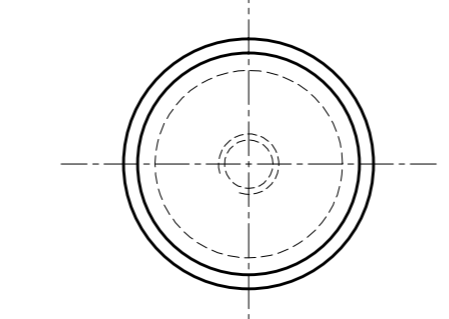
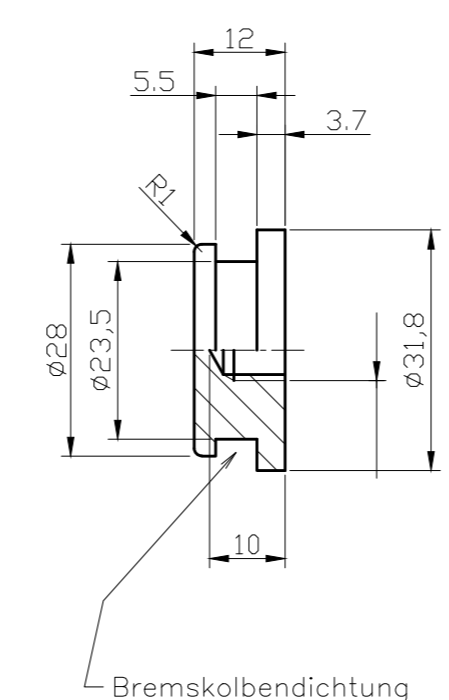
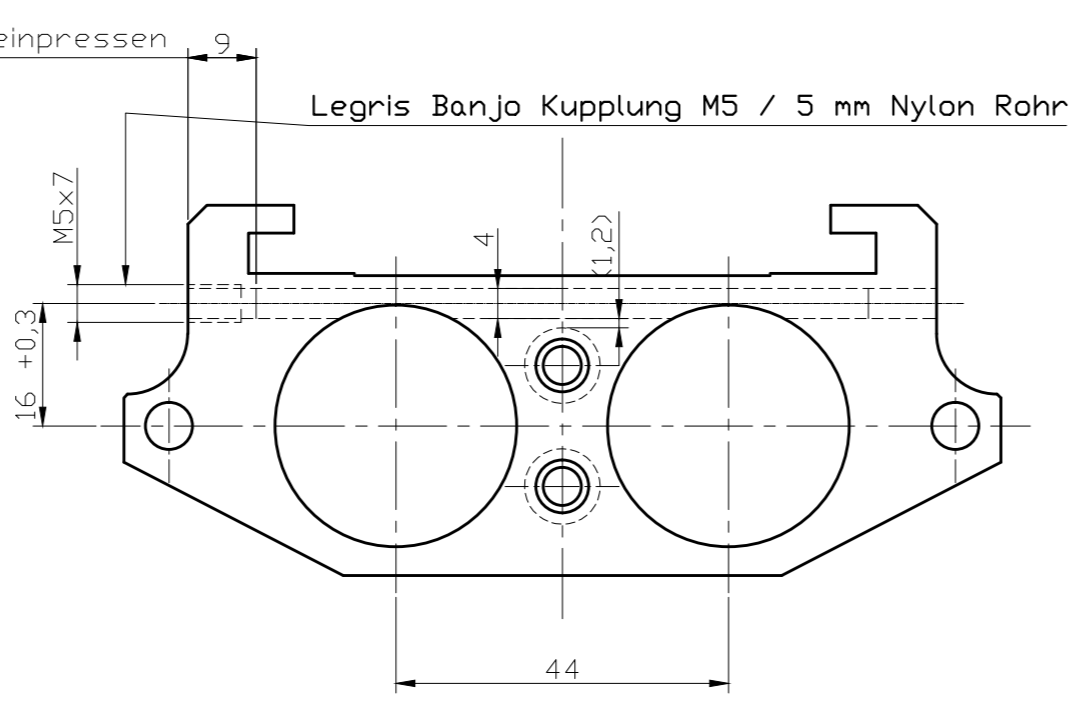
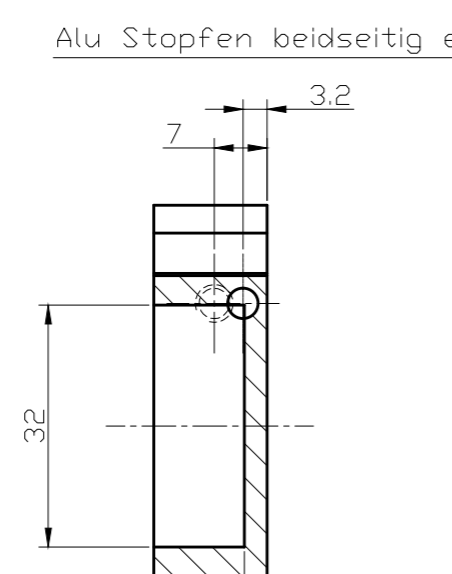
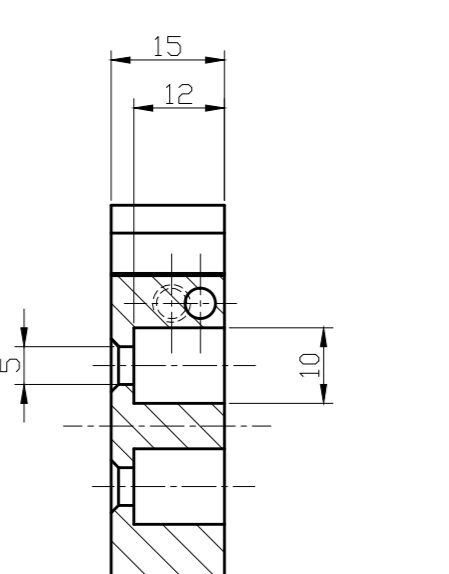
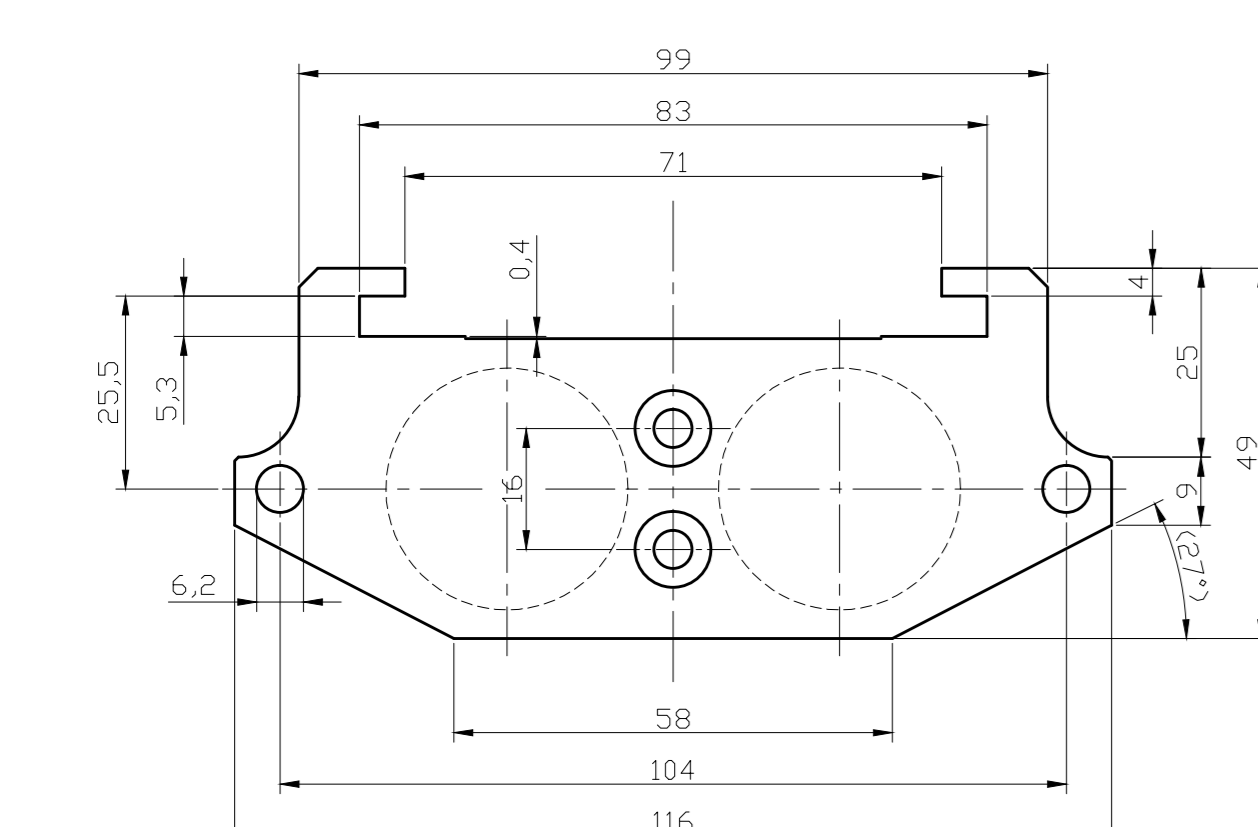
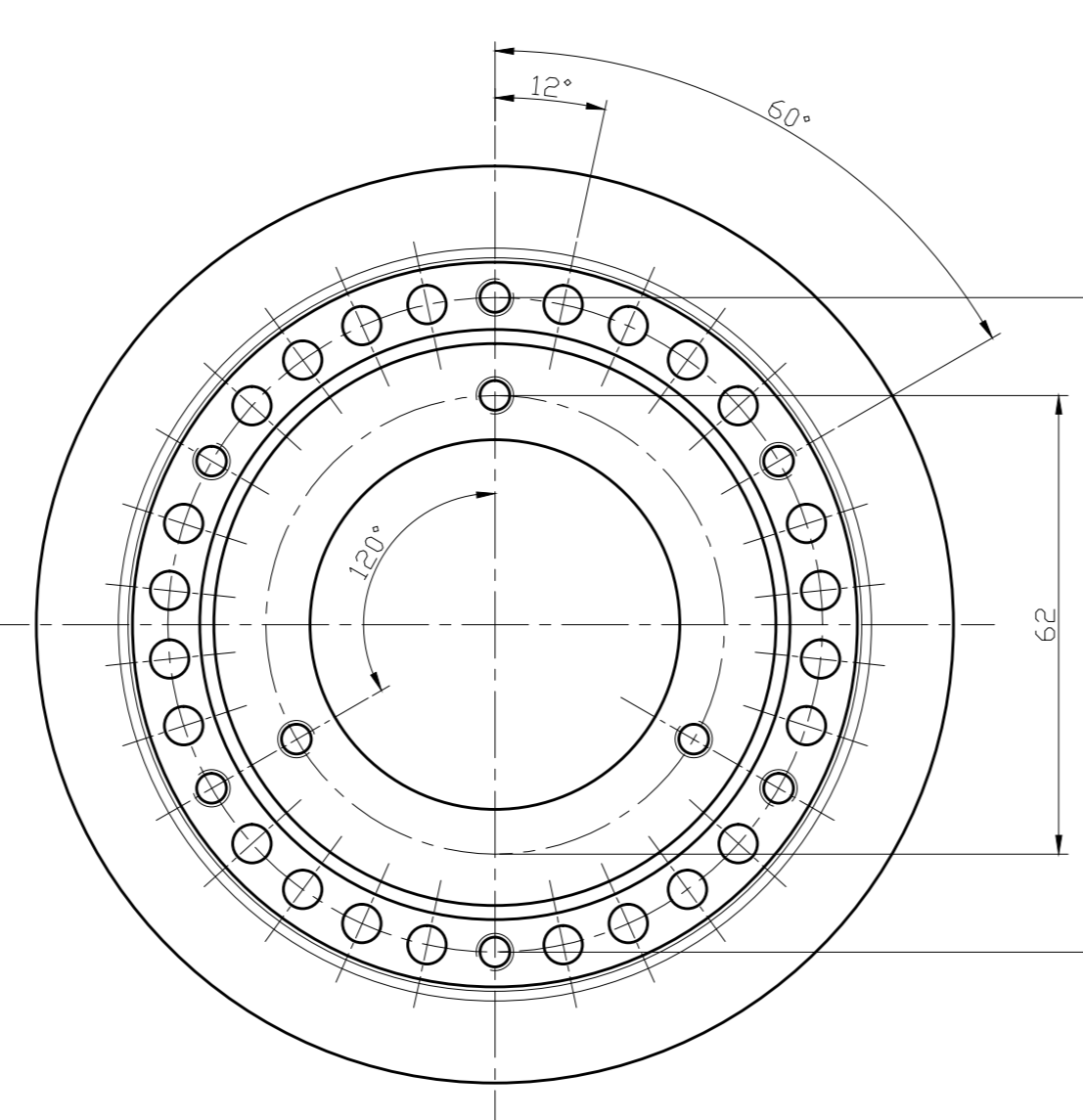
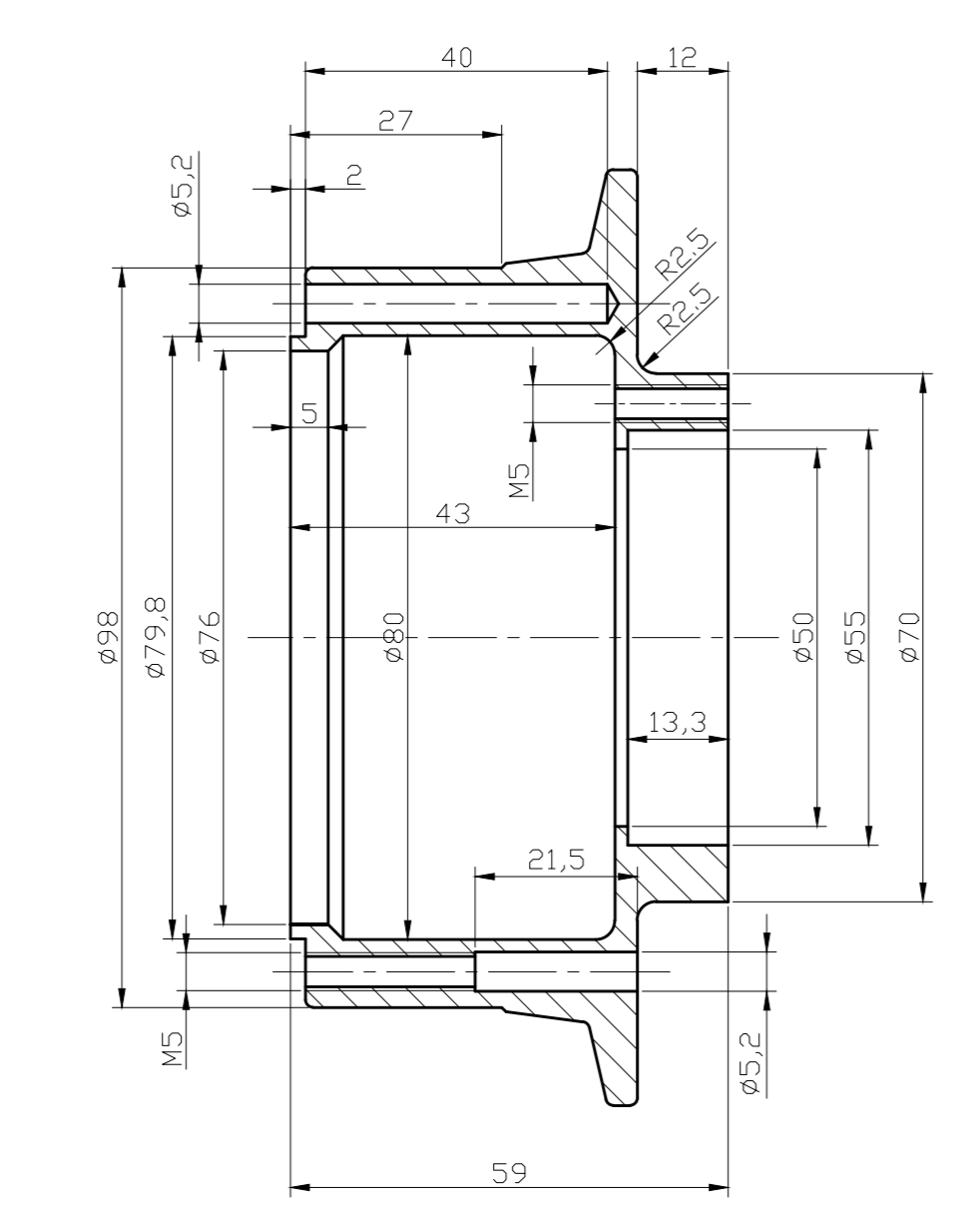
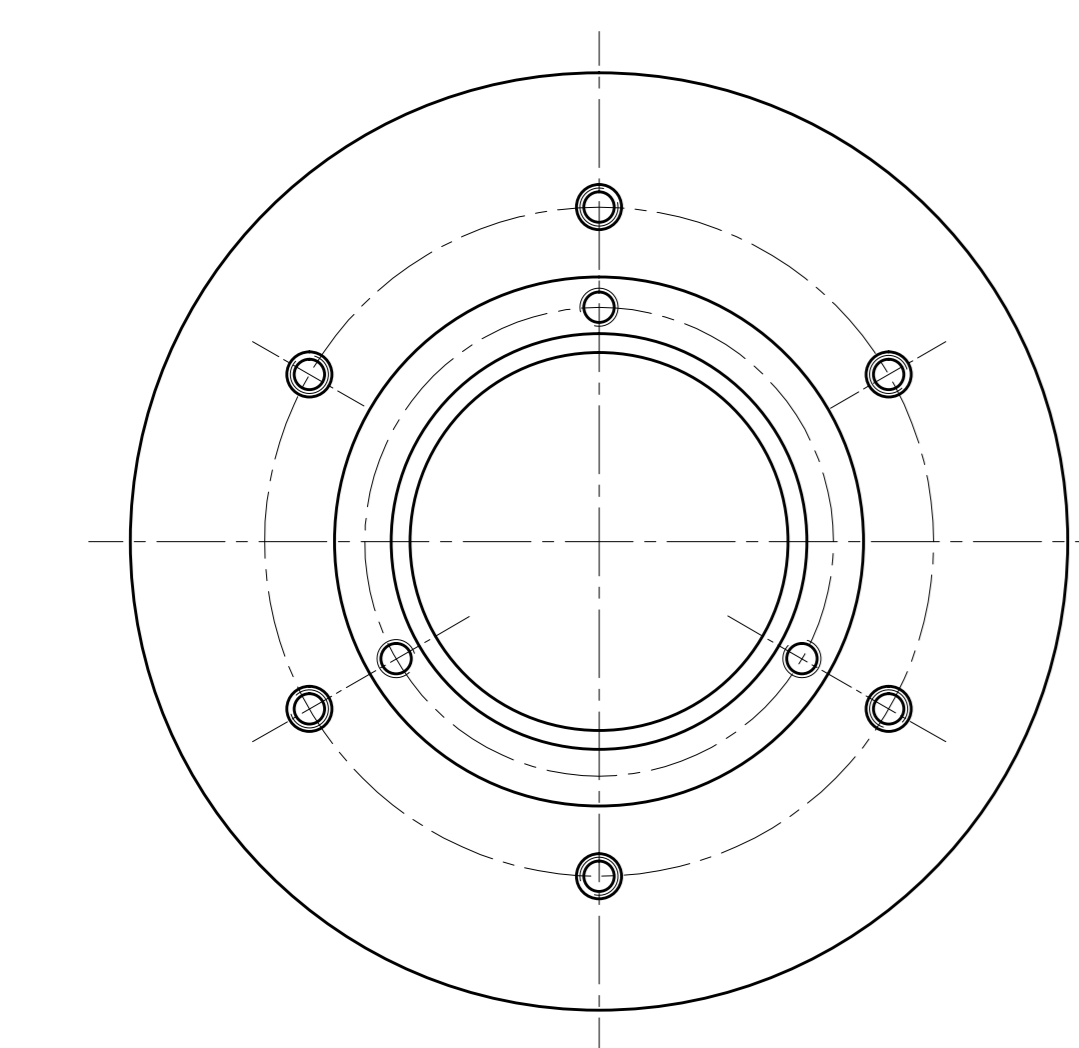
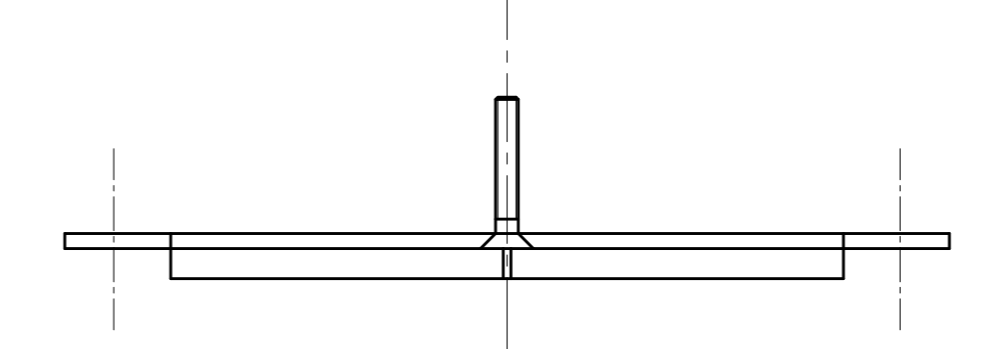
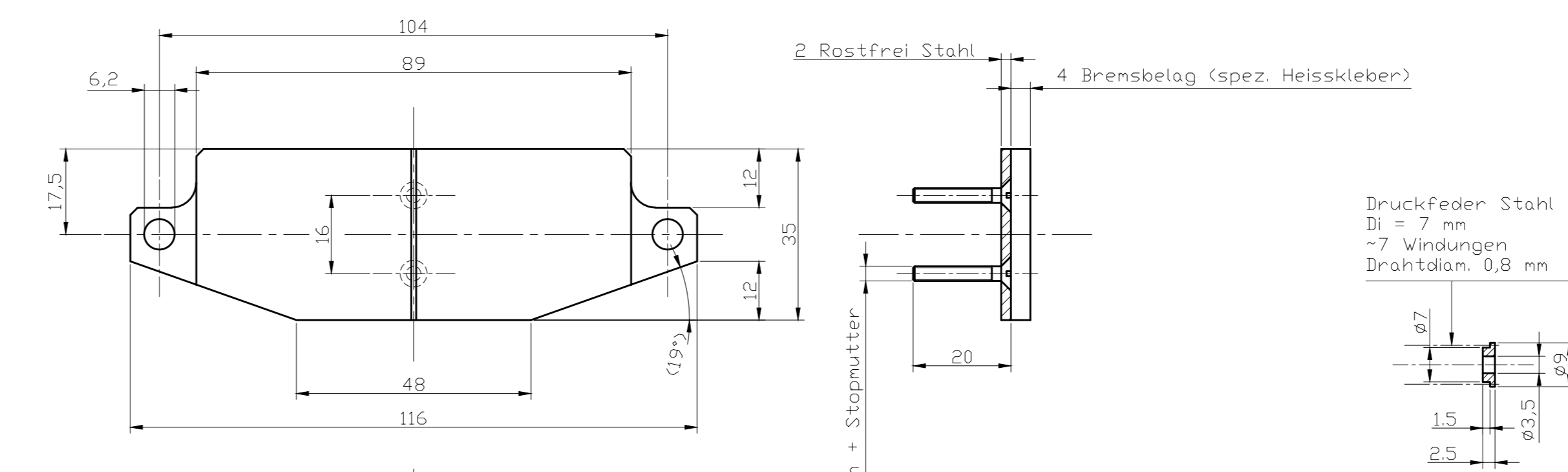
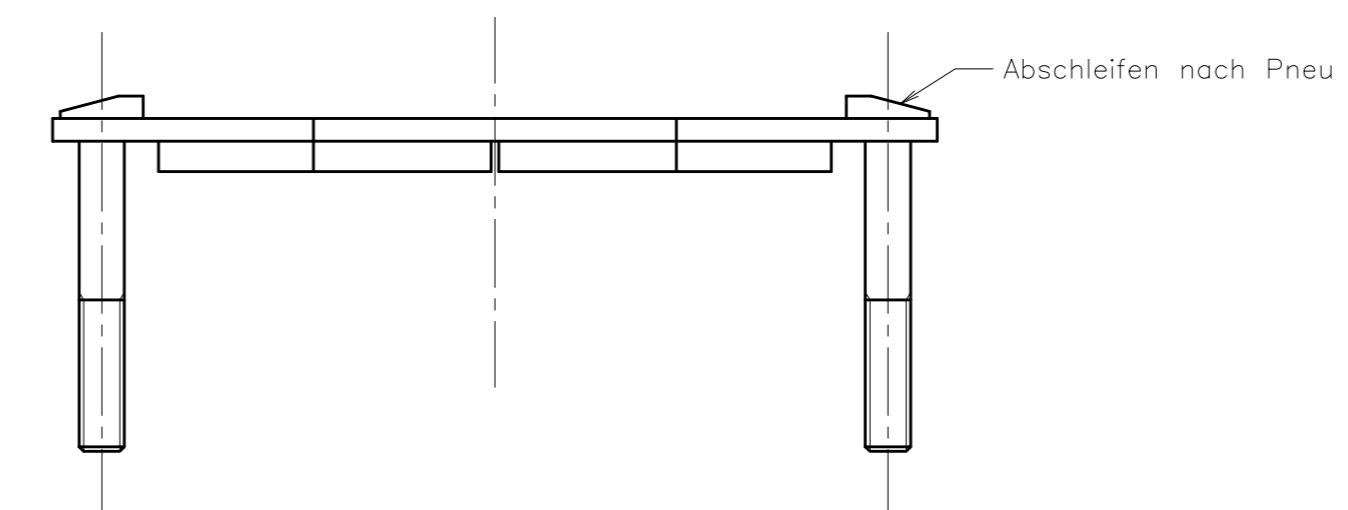
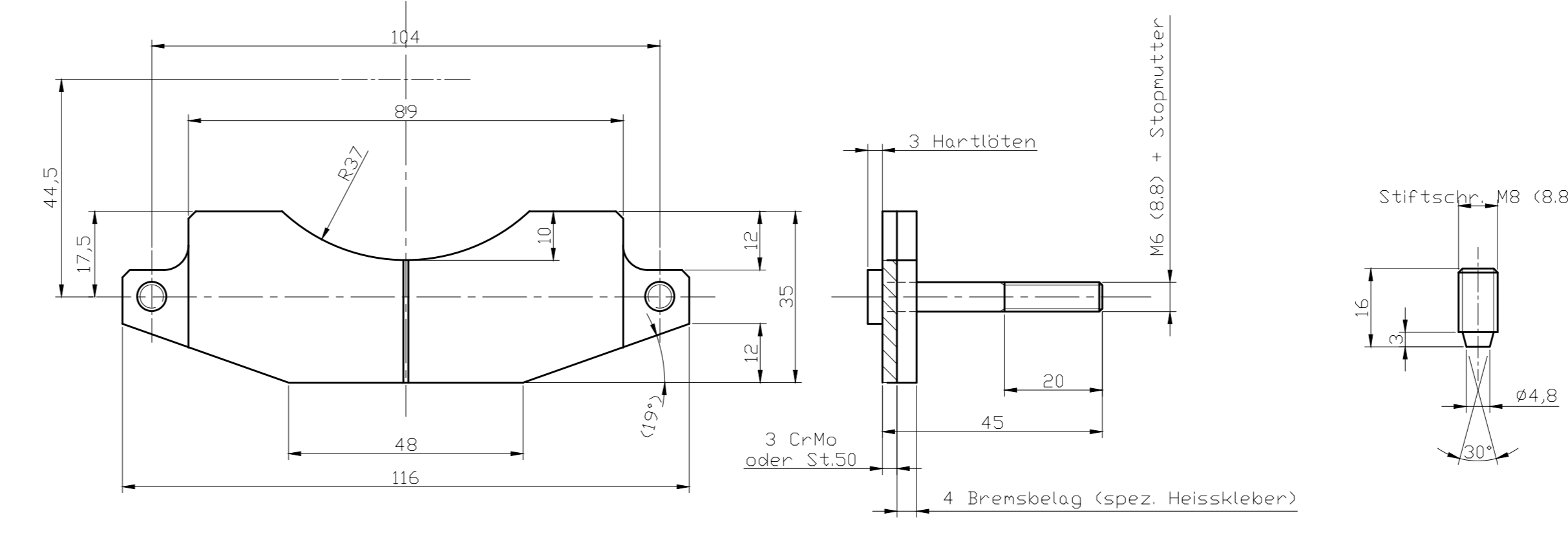
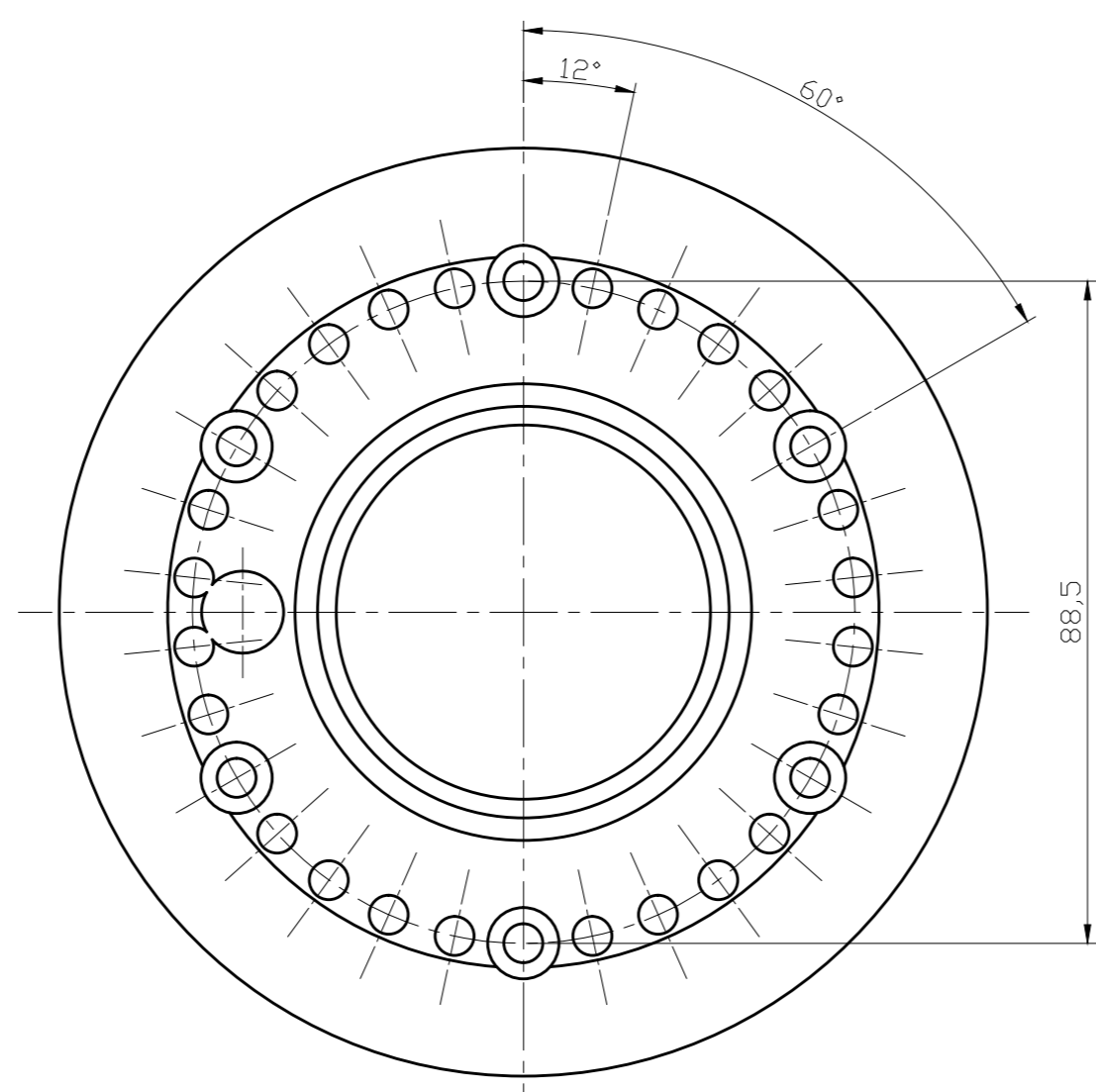
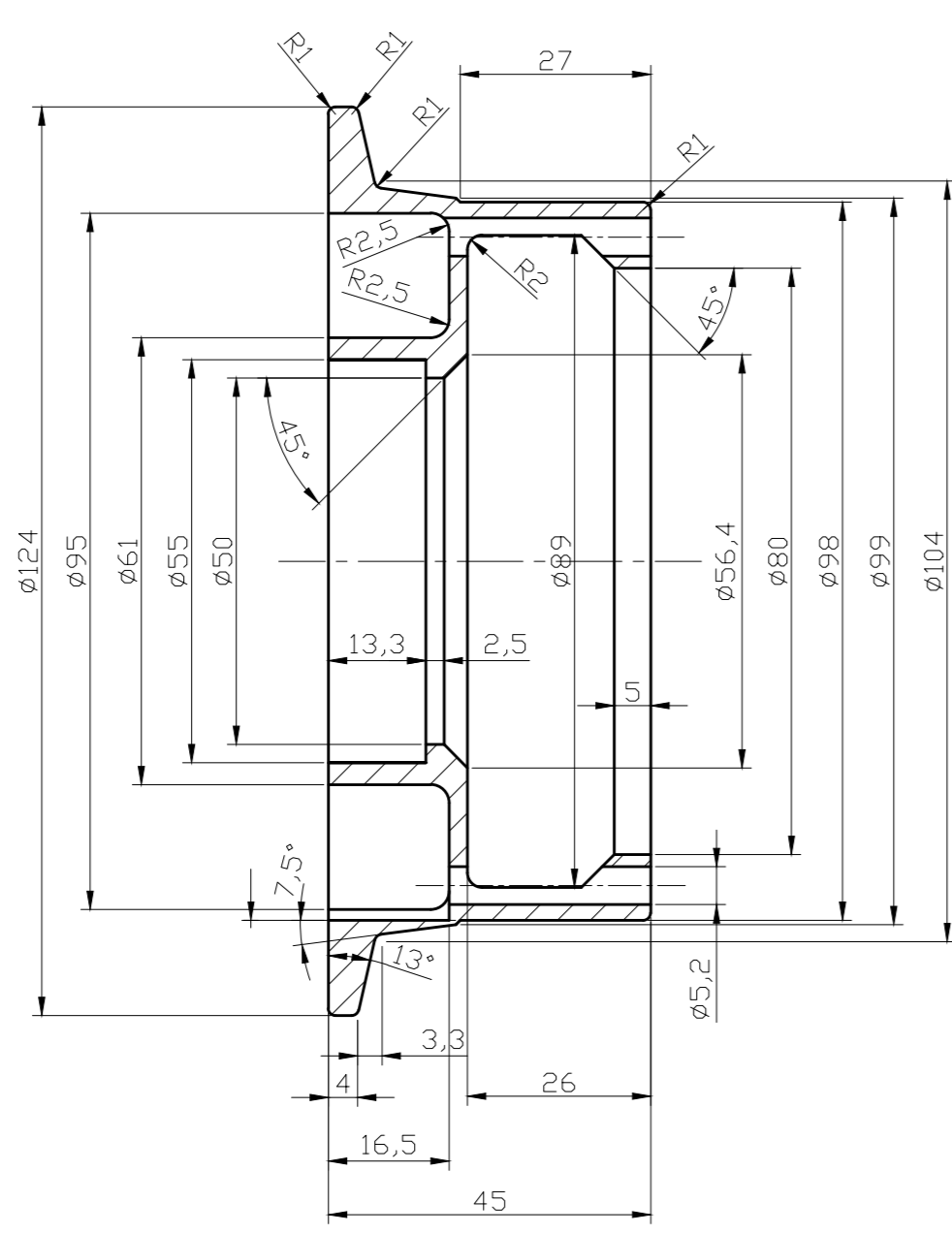
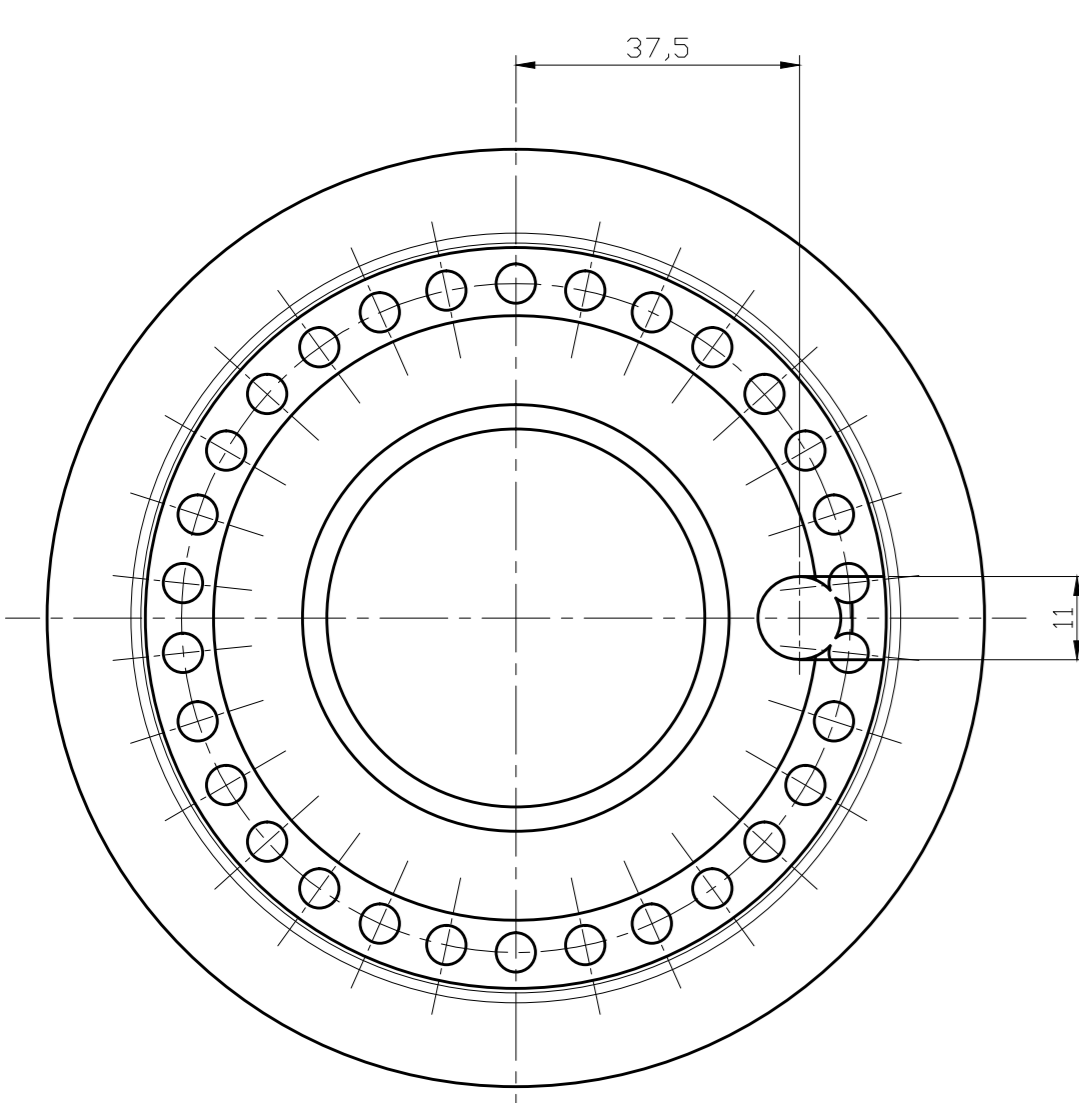
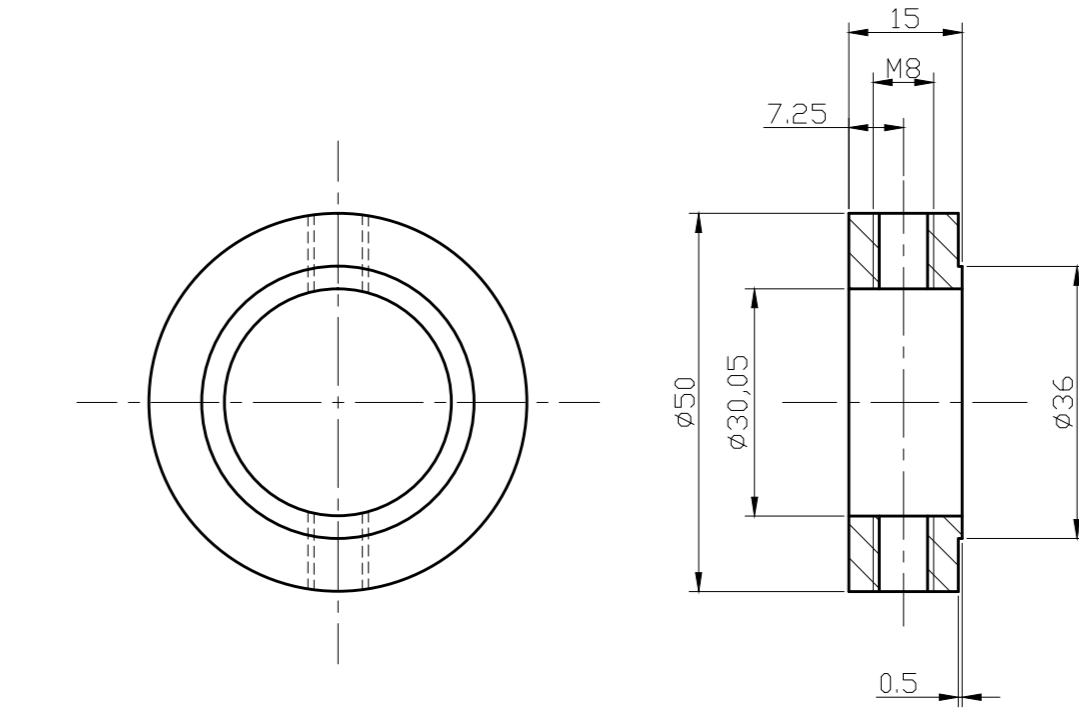
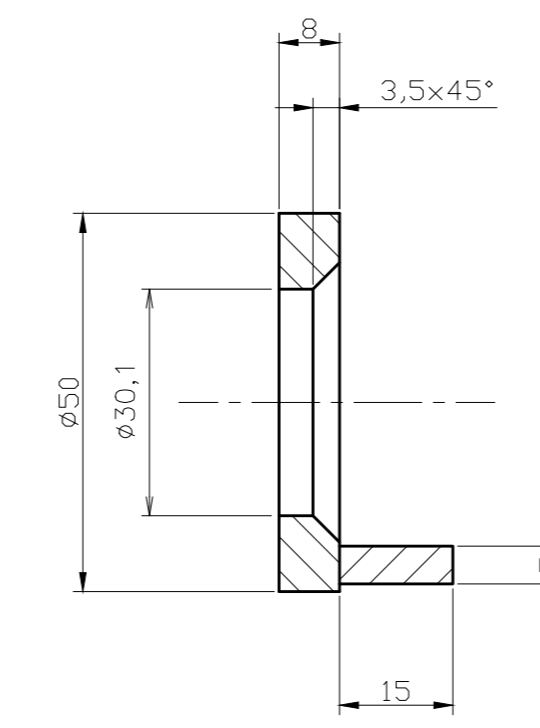
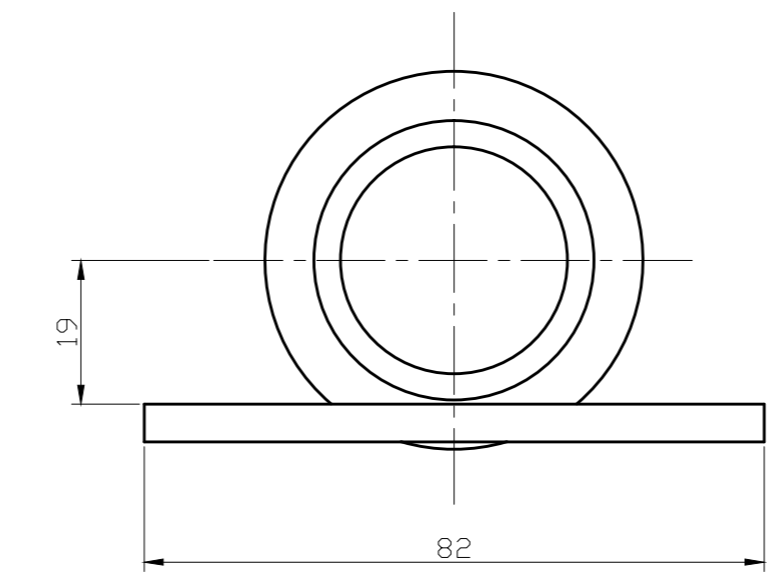
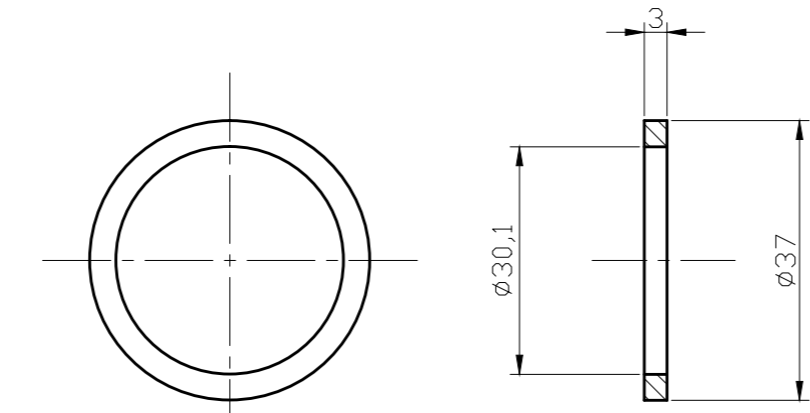

ST.NR.	ANT.	BENAMUNG	MATERIAL	TEK.NR.	OPMERKUNG
ONTW.	Max Braendli	SCHAAL 1:1			
GET.	Jan Hermesen	DATUM 8-8-2005	T.D.		
BX-2 Haupttraeder mit Bremsen					
Cherry	BX-2 Aviation Hoeheweg 2, CH-2553 Safnern, Schweiz				B.B.